



Vapor-Fas™ 62-05

Application and Installation Guide

FOR PROFESSIONAL USE ONLY

This information is intended only for experienced professionals familiar with techniques and installation of insulation jacketing materials. This guide is not sufficient to provide an installer with all the techniques, information and requirements necessary for the proper installation of the jacketing or insulation systems. There are many factors that may affect the job performance and the installer must consider all job parameters and determine fitness for use of the product as well as ensure that the product is installed to ensure a water and vapor tight system.

PREPARATION

Apply only to clean, dry, oil-free surfaces. Dirt, dust and loose insulation must be removed prior to application. Insulation surface should be as smooth as possible to provide a neat, even, finished appearance. All underlying insulation seams and longitudinal and butt joints must be taped with a compatible tape recommended by the insulation manufacturer. Ensure any HVAC ductwork is fully sealed against air leaks.

APPLICATION

PIPING

Vapor-Fas™ 62-05 jacketing is best applied by cigarette wrapping on piping. Cut membrane to desired length. Ensure length includes a minimum 3" (76 mm) overlap. For best finished appearance, keep the machine direction of all pieces of Vapor-Fas™ aligned in the same direction. Start by positioning the membrane such that the finished overlap will allow for water to drain over and not into the lap. Peel back six to twelve inches of the release liner, taking care not to allow any exposed adhesive to touch itself. Firmly press exposed edge of sheet in place and continue removing release liner and smoothing sheet to substrate. Avoid wrinkling.

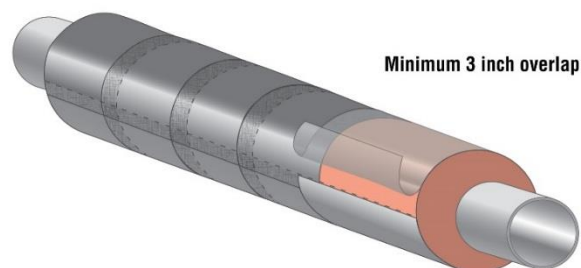

All longitudinal and circumferential seams must be overlapped a minimum of 3" (75 mm). Ensure complete contact at the laps and to the substrate using a tape squeegee or roller, applying firm pressure throughout.

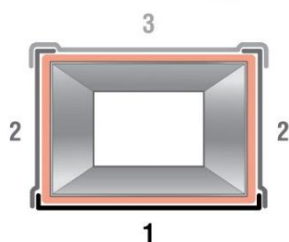
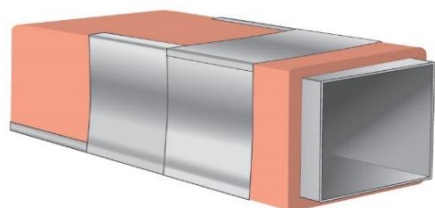

RECTANGULAR DUCT WORK

The top of rectangular duct work shall be sloped to avoid ponding water and ensure run-off.

Weld pin caps and washers shall be covered with a 3.9" x 3.9" (100 mm x 100 mm) piece of Vapor-Fas™ tape prior to the installation of the outer Vapor-Fas™ jacketing.

Pieces of jacketing should be cut and applied to ensure complete water drainage over and not into the laps. For fast and easy application, Vapor-Fas™ should be first applied to the bottom surface, then each side separately, and last the top. This ensures adequate coverage and avoids any open laps where water could drain into.

The bottom piece should be cut and applied first such that it extends a minimum of 3" up the sides of the duct. Side pieces should be cut next to cover the entire side of the duct from top to bottom. Finally, a top piece should be cut and applied, covering the entire top surface and extending a minimum 3" down the sides. Alternatively, for smaller duct, one or two pieces of jacketing may be used, ensuring that all final laps are overlapped a minimum of 3" and drain over the top.

H.B. Fuller Construction Products Inc.

ELBOWS AND BENDS

For elbows and bends, follow procedures used for fitting metal jacketing by cutting gores from the roll of Vapor-Fas™ jacketing to fit the insulation radius and diameter. Cut out the required shapes and apply to cover the segments of the bends and elbows. All fittings should be cut to allow for 2" (51 mm) overlaps. Cut feathers or slits into underlaps or overlaps to avoid wrinkles when changing dimensions of fittings require it. Where 2" (51 mm) overlaps are not possible, butt the two fitted pieces up as tightly as possible, avoiding wrinkling of the sheet. Be certain that each butting overlap covers any slit so that water cannot penetrate in. Use tape strips as necessary to ensure vapor tight seal; use 3.9" (100 mm) strips of Vapor-Fas™ jacketing to seal all joints a minimum of 1.9" (48 mm) overlap on both sides. Use care to ensure all fittings are completely vapor sealed. Alternately, strips of Vapor-Fas™ tape may be used to spiral wrap elbows if the configuration allows it.

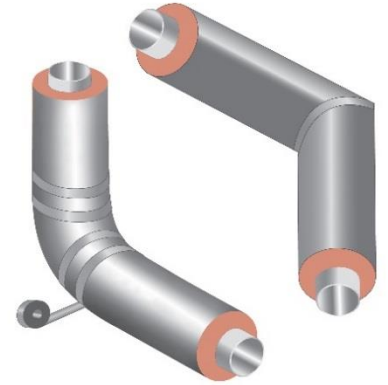

RECTANGULAR DUCTWORK REDUCERS

For rectangular ductwork reducers, Vapor-Fas™ jacketing should be applied from the bottom to the top and overlapping a minimum of 3 inches (76 mm) onto adjacent surfaces. This application will ensure proper adhesion and avoids wrinkling of the jacketing and any open laps where water could drain into.

Starting with the bottom surface of the ductwork reducer insulation (1), apply the Vapor-Fas™ jacketing and overlap onto the sides of the reducer (2) and onto both the smaller and larger duct sections (3 and 5). Next, apply the jacketing onto the sides of the reducer (2) and overlap onto the top of the reducer (4) and onto both the smaller and larger duct sections (3 and 5). Next, apply the Vapor-Fas™ jacketing onto the smaller duct section (3), starting with the bottom, then the sides, then the top, overlapping the jacketing that was already applied onto the bottom (1) and the sides (2) of the reducer. Next, apply the jacketing to the top of the reducer (4), overlapping onto the top of the smaller and larger duct sections (3 and 5). Next, apply the Vapor-Fas™ jacketing to the larger duct section (5), starting with the bottom, then the sides, then the top. Last, apply a butt strip over tab of the top of the reducer (4) and onto the smaller duct section (3).

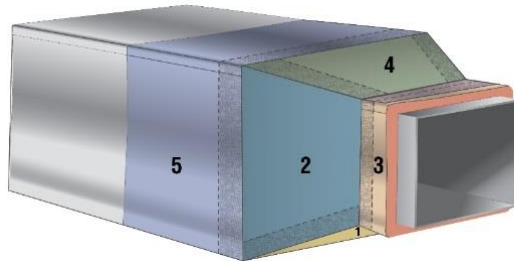

- 1 OVERLAP onto insulation 2, 3, and 5
- 2 OVERLAP onto insulation 3, 4, and 5
- 3 Apply bottom, sides, top in that order, overlapping tabs from 1 and 2
- 4 OVERLAP onto insulation 5, and overlapping onto piece 3
- 5 Apply bottom, sides, top in that order
- 6 Apply butt strip over tab of 4 and onto 3

ROUND DUCTWORK AND PIPING REDUCERS

For round ductwork and piping reducers, Vapor-Fas™ jacketing is best applied by cigarette wrapping. Ensure length includes a minimum 3" (76 mm) overlap. Make sure that the finished overlap will allow for water to drain over the lap.

First, apply jacketing to the smaller section of pipe directly after the reducer (1) and overlap onto the reducer (2), cutting feathers as necessary. Using the figure shown to the left, cut the jacketing in order to fit to the reducer, cutting slits into both curves of the piece, which helps give the jacketing flexibility and avoids wrinkling when applied on the curved section. Next, apply Vapor-Fas™ jacketing to the reducer (2) and overlap onto the smaller pipe section (1). Next, apply jacketing to the larger pipe section (3) and overlap onto the reducer (2). Last, continue applying Vapor-Fas™ to the smaller pipe (4), making sure to overlap at least 3" (76 mm) onto any previously applied jacketing.

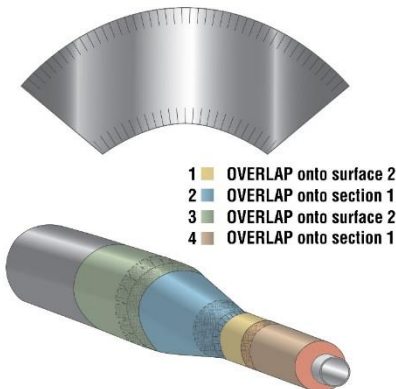

- 1 OVERLAP onto surface 2
- 2 OVERLAP onto section 1
- 3 OVERLAP onto surface 2
- 4 OVERLAP onto section 1

Alternately, strips of Vapor-Fas™ tape may be used to spiral wrap reducers if the configuration allows it.

H.B. Fuller Construction Products Inc.

1105 South Frontenac St ○ Aurora, IL 60504 ○ 800-832-9002 ○ fax 800-952-2368

TEE SECTIONS

For tees, follow procedures used for fitting metal jacketing by cutting gores, legs, sine waves and C-collars from the roll of Vapor-Fas™ jacketing to fit the insulation radius and diameter. All fittings should be cut to allow for 2" (51 mm) overlaps.

Using the figure shown to the right, cut pieces 1 and 2. As shown in piece 1, cut slits into the curves, which avoids wrinkling of the jacketing when it overlaps onto the pipe tee (2). Apply piece 1 first, overlapping the jacketing at least 2" (51 mm) when wrapped around the pipe and onto the pipe tee (2). Then apply piece 2 to the pipe tee, overlapping the jacketing at least 2" (51 mm) when wrapped around the pipe. Use care to ensure all fittings are completely vapor sealed.

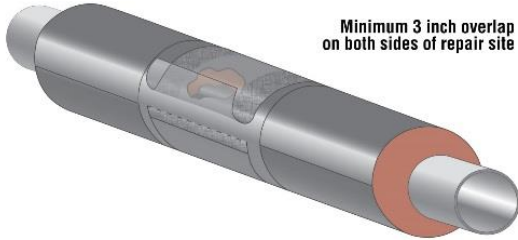
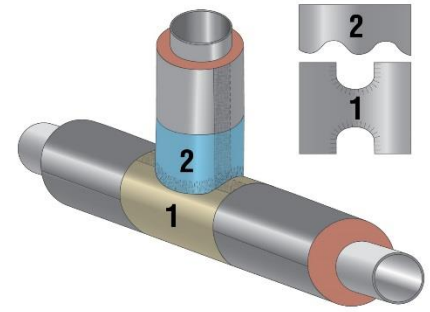

Minimum 3 inch overlap
on both sides of repair site

REPAIRS

If any section of jacketing should be damaged, cut out the damaged section and patch it with new jacketing over the empty section. Make sure to overlap the existing sheet by a minimum of 3" (76 mm) all the way around the repaired area. Position the membrane such that the finished overlap will allow for water to drain over and not into the lap.

TIPS AND SUGGESTIONS

When Vapor-Fas™ jacketing is applied over rubber foam or other insulations that may expand and contract as a result of temperature fluctuations from exterior exposure or system cycling, all overlaps shall be sealed by an additional 3.9" (100 mm) wide tape strip spanning over the laps

All penetrations, insulation supports, valves, expansion and contraction joints and other protrusions must be properly flashed to ensure complete seal between the protrusion and the jacketing. Foster® 95-44 Elastolar® Sealant or 95-88 Elastiseal™ Sealant may be flashed directly over the jacketing.

On low temperature applications, ensure the insulation and jacketing are free from frost or condensation. Apply the jacketing as normal, ensuring good adhesion at all overlaps. At temperatures below 20°F (-7°C), a heat gun and squeegee or roller are suggested to warm the sheet and obtain optimal adhesion at the overlaps.

To improve adhesion to dusty insulations, such as PIR, the insulation may be primed with Foster® 85-45 Fos-Stik™ Aerosol Adhesive.

When applying Vapor-Fas™ jacketing over PIR pipe insulation greater than 4" (102 mm) pipe diameter, follow insulation manufacturers' recommendations for additional mechanical fastening.

FOR PROFESSIONAL USE ONLY

The information contained in this application guide has been prepared in good faith on the basis of information available at the time of publication. The accuracy or completeness of the information is not guaranteed. It is for guidance only. Use of this information in any way is the sole responsibility of the user. The information is intended only for experienced professionals familiar with techniques and applications of insulation jacketing materials. There are many factors that may affect the job performance and the installer must consider all job parameters and determine fitness for use of the product as well as ensure that the product is installed to ensure a water and vapor tight system.

IMPORTANT: H.B. Fuller Construction Products Inc. warrants that each of its products will be manufactured in accordance with the specifications in effect on the date of manufacture. WE MAKE NO OTHER WARRANTIES AND EXPRESSLY DISCLAIM ANY WARRANTIES OF MERCHANTABILITY OR FITNESS FOR A PARTICULAR PURPOSE. If a product fails to meet this limited warranty, purchaser's sole and exclusive remedy is replacement of the product or, at our option, refund of the purchase price. OUR ACCEPTANCE OF ANY ORDERS FOR THE PRODUCT IS EXPRESSLY CONDITIONAL UPON PURCHASER'S ASSENT TO THE TERMS ON THE APPLICABLE INVOICE.

ADEQUATE TESTS: The information contained herein we believe is correct to the best of our knowledge and tests. The recommendations and suggestions herein are made without guarantee or representation as to results. We recommend that adequate tests be performed by you to determine if this product meets all of your requirements.

H.B. Fuller Construction Products Inc.

1105 South Frontenac St ○ Aurora, IL 60504 ○ 800-832-9002 ○ fax 800-952-2368